



# DESIGN NOTES

## Precision Receiver Delay Improves Data Transmission

Design Note 129

Victor Fleury

Moving data from one board to another over a backplane places stringent requirements on channel-to-channel and part-to-part skew and delay. The propagation delay of typical CMOS line receivers can vary as much as 500% over process and temperature. In high speed synchronous systems where clock and data signal timing are critical, transmission rates must often be reduced to minimize the effects of propagation delay and skew uncertainties in the receiver. The LTC<sup>®</sup>1518/LTC1519/LTC1520 family of high speed line receivers solves this problem, reducing propagation delay changes to less than  $\pm 17\%$  over production variations and temperature, a better than 10 times improvement over previous solutions.

The LTC1518/LTC1519/LTC1520 family of 50Mbps quad line receivers translate differential input signals into CMOS/TTL output logic levels. The receivers employ a unique architecture that guarantees excellent performance over process and temperature with propagation delay of 18ns  $\pm 3$ ns. The architecture affords low same channel skew ( $|t_{PHL} - t_{PLH}|$  500ps typ), and low channel-to-channel propagation delay variation (400ps typ). The propagation delay and skew performance are unmatched by any CMOS, TTL or ECL line receiver/comparator.

### Circuit Description

Figure 1 shows a block diagram of the LTC1520 signal path. The input differential pair amplifies the minimum 500mV input signal level. A resistor network expands the input common mode range of the LTC1520 from 0V to 5V, and expands that of the LTC1518/LTC1519 from  $-7$ V to 12V while operating on a single 5V supply. A second differential amplifier ( $g_m$ ) switches a fixed current into its load capacitance. The output of the second stage is a valid logic level that feeds inverters.

To guarantee tight delay and skew performance, delay within each receiver and between channels must be carefully matched. For the LTC1518/LTC1519/LTC1520, the inherent temperature and process tolerance, along with bias and delay trimming, make it possible to guarantee a propagation delay window more than an order of magnitude tighter than that of the typical CMOS line receiver. Since skew is caused by the unequal charging versus discharging of both internal and external capacitances, the first stages are differential to minimize these effects.

LTC, LTC and LT are registered trademarks of Linear Technology Corporation.

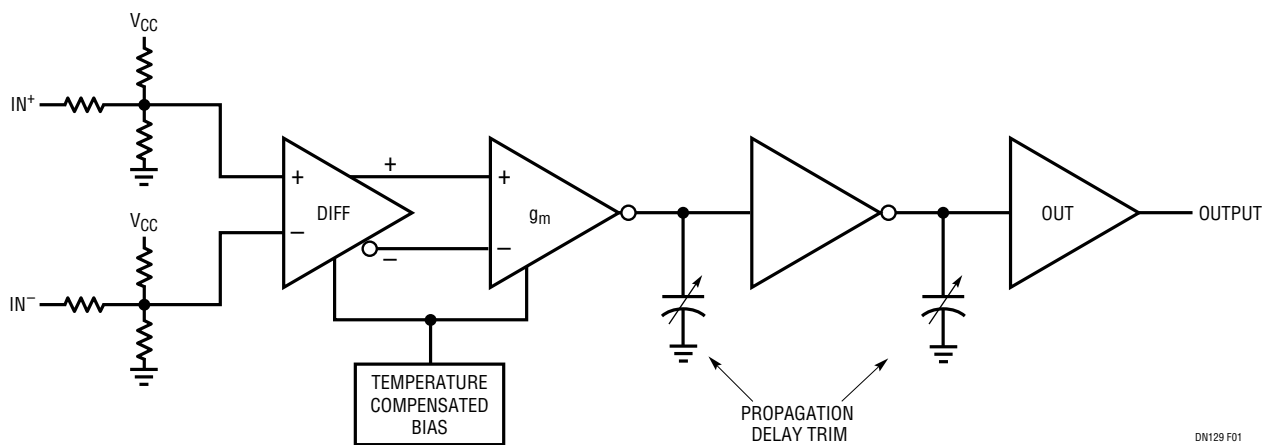

Figure 1. LTC1520 Block Diagram

### Additional Features

Other features include novel short-circuit protection. If the output remains in the wrong state for longer than 60ns, the output current is throttled back to 20mA. When the short is removed and the output returns to the correct state, full output drive is restored. Because of its high input impedance (even when unpowered), the LTC1518/LTC1519/LTC1520 can be "hot swapped" without corrupting backplane signal integrity or causing latchup. The outputs remain high with shorted or floating inputs (LTC1518/LTC1519 only) and can be disabled to a high impedance state. High input resistance ( $\geq 18k$ ) also allows multiple parallel receivers.

### Applications

The LTC1520 is designed for high speed data/clock transmission over short to medium distances. Its rail-to-rail input common mode range allows it to be driven via long PC board traces, coaxial lines or long (hundreds of feet) twisted pairs. Figure 2 shows the LTC1520 in a backplane application. 5V single-ended signals are received with a 2.5V slicing threshold. This configuration can be adapted as a coaxial receiver. In Figure 3, the LTC1518 is shown in an RS485-like application, but capable of operating at up to 50Mbps, limited only by cable characteristics.

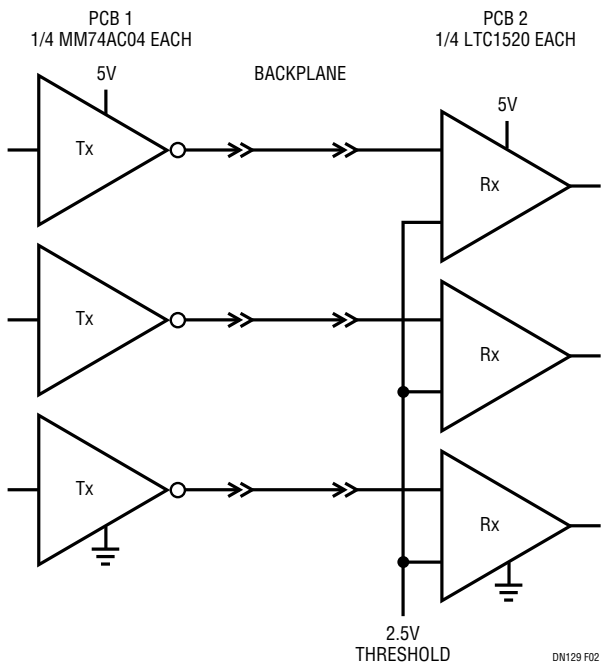

Figure 2

Figure 4 shows actual waveforms of the LTC1518 connected in the Figure 3 configuration (100 feet of unshielded twisted pair was used). Note that the delay of the twisted pair is almost 200ns versus the receiver's 18ns delay.

The waveforms of Figure 5 show 50Mbps operation using the LTC1518 with 100 feet of twisted pair.

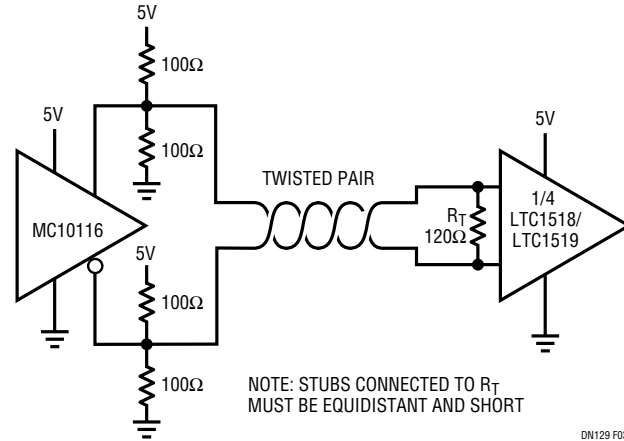

Figure 3. LTC1518 Typical Application

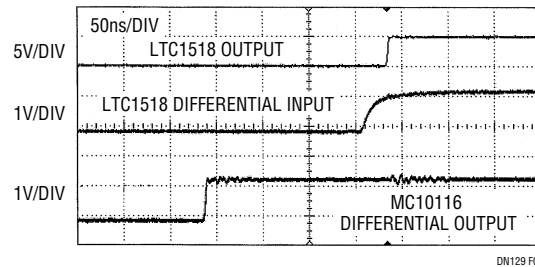

Figure 4. LTC1518 100 Feet Twisted-Pair Connection

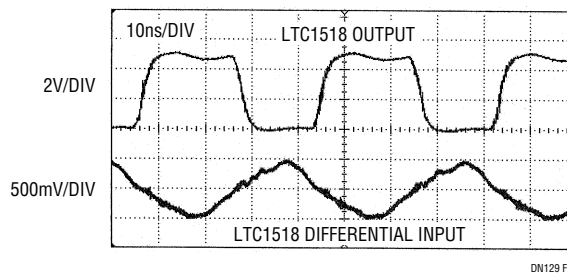

Figure 5. 50Mbps Operation Using 100 Feet of Twisted Pair

For literature on our High Speed Receivers, call **1-800-4-LINEAR**. For applications help, call (408) 432-1900, Ext. 2453